

# ALCATEL

home & business phones

**Alcatel XPS4010<sup>+</sup>**



USER'S GUIDE

使用說明書

## 目錄

<b>English Version</b> .....	21
<b>配件清單</b> .....	4
<b>使用注意事項</b> .....	5
<b>安全預防措施</b> .....	5
<b>座機安裝步驟</b> .....	5
<b>座機規格與功能說明</b> .....	6
<b>手機規格說明</b> .....	7
<b>手機面板說明</b> .....	8
<b>待機模式</b> .....	9
<b>接聽電話</b> .....	9
<b>撥打電話</b> .....	9
<b>通話時</b> .....	9
通話計時器.....	9
調整手機音量.....	9
接聽插播電話.....	9
重撥功能.....	10
撥打內線電話.....	10
接聽內線電話.....	10
在使用內線電話時接聽外線電話.....	10
在與外線通話時撥打內線電話.....	10
<b>免持功能</b> .....	11
<b>電話簿操作</b> .....	11
瀏覽電話簿資料.....	11
儲存電話簿資料.....	11
電話按鍵相對應字元.....	11
從電話簿撥打電話.....	12
編輯電話簿中現有的電話號碼.....	12
刪除電話簿中的單筆資料.....	12
<b>來電顯示功能</b> .....	12
當有來電時檢視來電者的資訊.....	12
檢視來電記錄.....	13
從來電者清單撥打電話.....	13
<b>註冊登錄</b> .....	13
<b>刪除手機</b> .....	13
<b>選擇外線撥出電話功能</b> .....	14
<b>手機功能設定</b> .....	14
手機鈴聲設定.....	14

設定外鈴聲類型及音量.....	14
設定內鈴聲類型及音量.....	14
手機語言設定.....	14
手機對比設定.....	15
手機鬧鐘設定.....	15
手機按鍵音設定.....	15
手機自動應答設定.....	15
手機按鍵鎖設定.....	15
手機 REDIAL 鍵功能說明.....	16
手機 R 鍵功能說明.....	16
還原話機設定.....	16
<b>座機功能設定.....</b>	<b>16</b>
時間設定.....	16
還原主機設定.....	16
插接音.....	16
語音提示功能.....	17
手機選單架構.....	17
<b>疑難排解指南.....</b>	<b>18</b>
<b>主要功能特點.....</b>	<b>19</b>
<b>技術規格.....</b>	<b>19</b>

# 配件清單

<p>1. 座機 1 台</p> 	<p>2. 手機 4 支</p> 
<p>3. 手機充電座 4 台</p> 	<p>4. 手機電池組 4 組(每組兩顆) 鎳氫電池 1.2V</p> 
<p>5. 電源變壓器 5 顆 (座機 1 顆, 手機充電座 4 顆) 座機規格:DC9V 0.5A 手機規格:DC7V 0.42A</p> 	<p>6. 電話線 4 條</p> 
<p>7. 保證書 1 張</p> 	<p>8. 使用說明書 1 本</p> 

## 使用注意事項

1. 請小心地將您的無線電話從包裝盒中取出。如發現明顯的損壞，請勿嘗試操作本產品。請將它退回至購買的地點。
2. 請檢查本無線電話系統的所有附件是否齊全。包裝盒中應包含手機、座機、變壓器、電池、電話線、及使用手冊。
3. 建議您不要將本裝置放置在其他設備的旁邊。這樣可能會導致干擾。
4. 本主機遵循歐規 DECT 之 GAP 標準，任何遵循該標準之手機均應能與本主機相容。增購手機時請向經銷商查明該手機是否符合以上標準。
5. 本系統之發射功率極低，可放置於室內任何地方長期使用均不至於對人體造成不利影響。但為提高傳輸距離，請將主機放置在較中間處而沒有障礙的位置。例如三層樓的透天房子，主機應放置在二樓且無障礙的地方。所謂障礙是指金屬或遮蔽物如鐵櫃、牆壁等。您可將主機置於木櫃、玻璃櫃內或天花板上，但不可置於金屬櫃內、金屬板上或被金屬板遮蔽。

## 安全預防措施

- XPS-4010<sup>+</sup>的手機須先在手機充電座上充足電力才能使用，充電座透過整流變壓器與 AC 電源插座相連。
  - 手機充電座和 XPS-4010<sup>+</sup>的主機都要接上 AC 變壓器才能運轉，停電時無線部分無法運作，可在外線端並連一台有線電話或購買 UPS 不斷電系統儲備電力。
  - 手機必須使用充電式鎳氫電池才能放在充電座上，若使用不能充電的電池切勿放在充電座上充電，如此將會導致短路，對手機和電池有嚴重的傷害。
  - 在充電過程中電池會逐漸發燙，這是正常狀況不造成任何威脅。
  - 避免充電座與金屬或潮濕表面接觸。
  - 廢棄之電池不能丟入火中焚燒或與一般家庭垃圾擺在一起，它們須放在適當的資源回收站。
- 因為電池對潮濕很敏感，不要把主機、充電座或手機放置在浴室、地下室或高溼度的地方。也避免接近發熱的儀器或陽光直接曝曬及太冷的地方。

## 座機安裝步驟

1. 將電源變壓器插頭接在電源插座上，9V DC 直流輸出端的圓形插頭插在座機背面標示 DC 9V 的插孔。
2. 將電信局的外線，插在座機背面標示 1, 2, 3, 4 的電話線插口(RJ-11)上。
3. 將手機註冊到座機上(出廠包裝的 4 支子機已登錄註冊好)，在座機無線電訊號的涵蓋範圍內可以使用無線手機與客戶或朋友通話聊天。
4. 本系統之發射功率極低，可放置於室內任何地方長期使用均不至於對人體造成不利影響。但為提高傳輸距離，請將座機放置在較中間處而沒有障礙的位置。例如三層樓的透天房子，座機應放置在二樓且無障礙的地方。所謂障礙是指金屬或遮蔽物如鐵櫃、牆壁等。您可將座機置於木櫃、玻璃櫃內或天花板上，但不可置於金屬櫃內、金屬板上或被金屬板遮蔽地方。

## 座機規格與功能說明

1. 具有四個外線 15 個內線小總機及基地台功能。
2. 同時具有四個空中通話頻道供四支手機同時使用。
3. 自動總機應答功能(DISA)。
4. 全數位化處理，高話音品質，不互相干擾，保密性高。
5. 座機電源輸入：110V AC 60Hz，變壓整流成 9V DC 0.5A。
6. 重量：410 公克
7. 尺寸：210x183x50mm

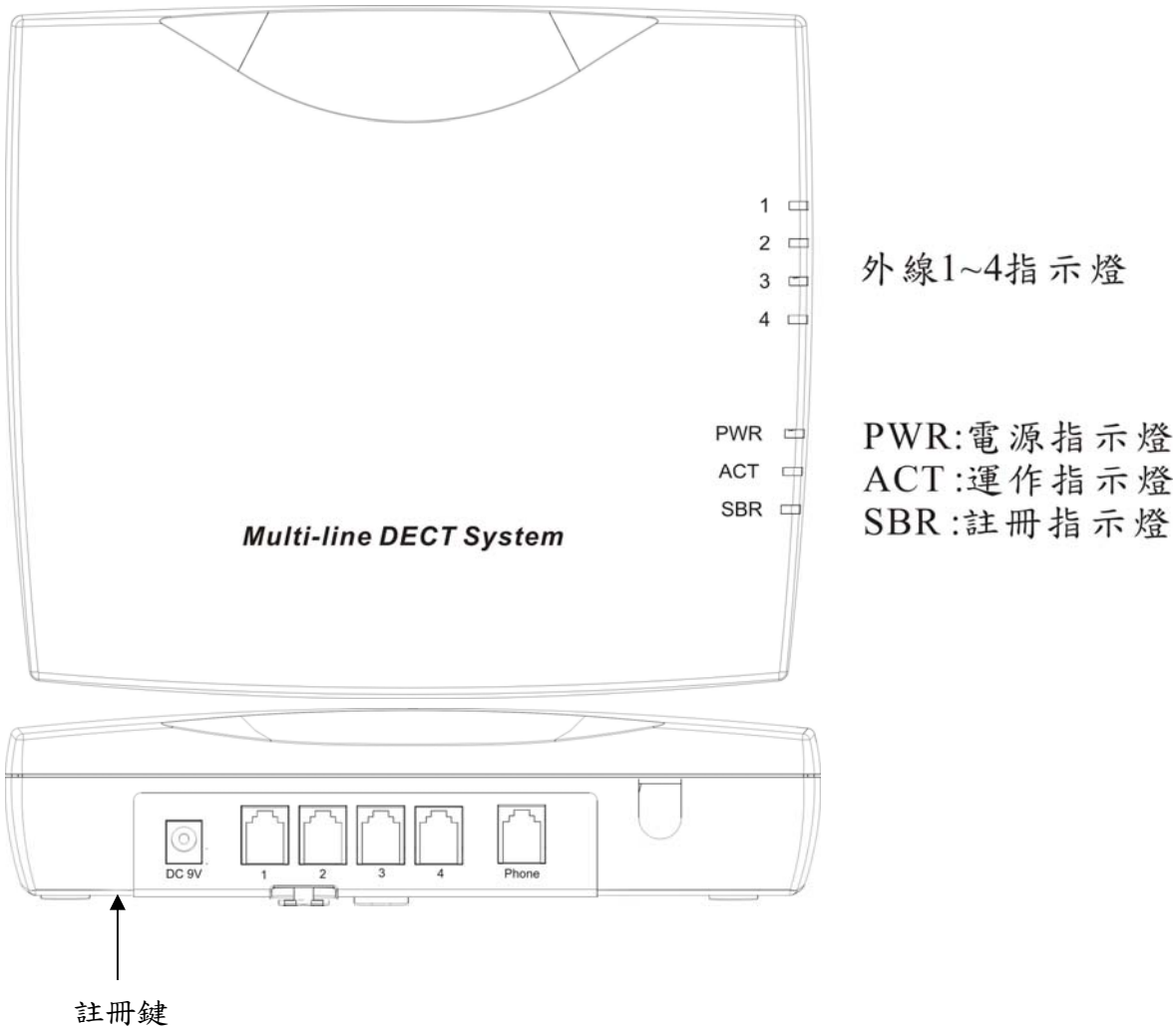

主機正面外線指示燈 1,2,3 及 4 在使用中時會亮燈。

**注意：**背面外線插孔 1,2,3 及 4 請確實插入電信局外線，主機接上電源開機時會自動偵測外線，如果主機正面的外線指示燈閃爍，表示該條外線沒有接好或電話線有問題，請重新插拔該條外線並請重開(插拔)主機電源，直到所有外線指示燈在熄滅狀態下。在正常使用下 XPS-4010<sup>+</sup>會在使用外線時偵測是否有聲音，所以在主機開機使用中請勿拔除外線，如果使用中拔除外線，該外線指示燈會變閃爍，此時您必須重新插上外線後再重開主機電源才能正確偵測。

## 手機規格說明

1. 手機充電器電源輸入：100V AC ~ 240V AC 50~60Hz，變壓整流成 7V DC 0.42A。
2. 使用鎳氫充電電池 AAA(4 號電池)兩顆。
3. 手機重量：140 公克。
4. 尺寸：長 169mm x 寬 48mm x 厚 23mm。

## 手機充電器

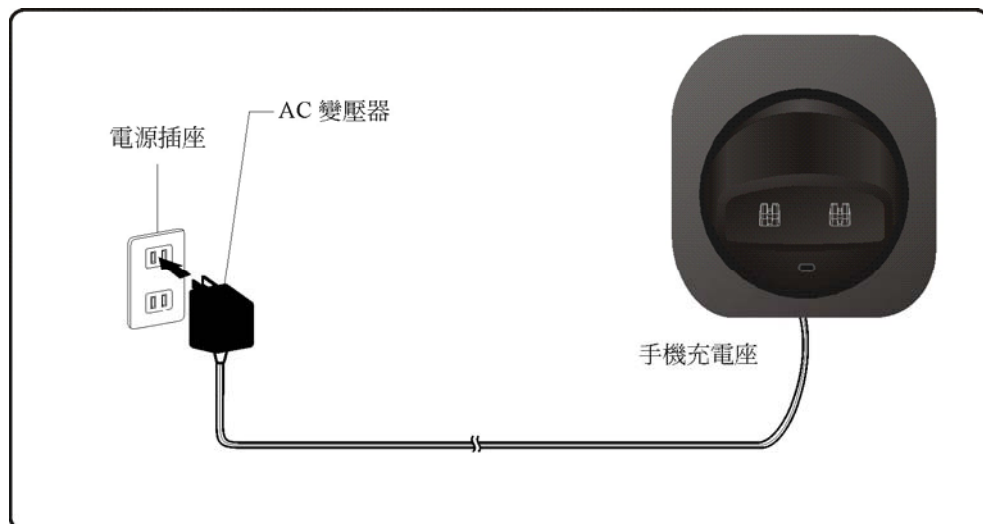

## 手機電池背蓋

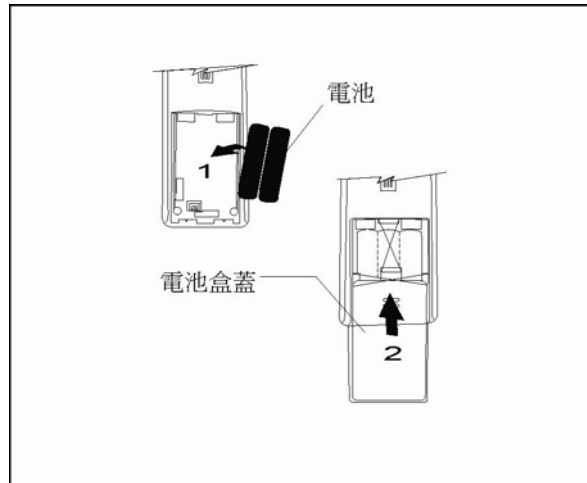

1. 安裝手機電池，請將電池依方向放入電池盒內。
2. 蓋上手機電池蓋並推緊密合。

重要事項：在第一次使用之前，請先將手機充電 12 個小時。

# 手機面板說明

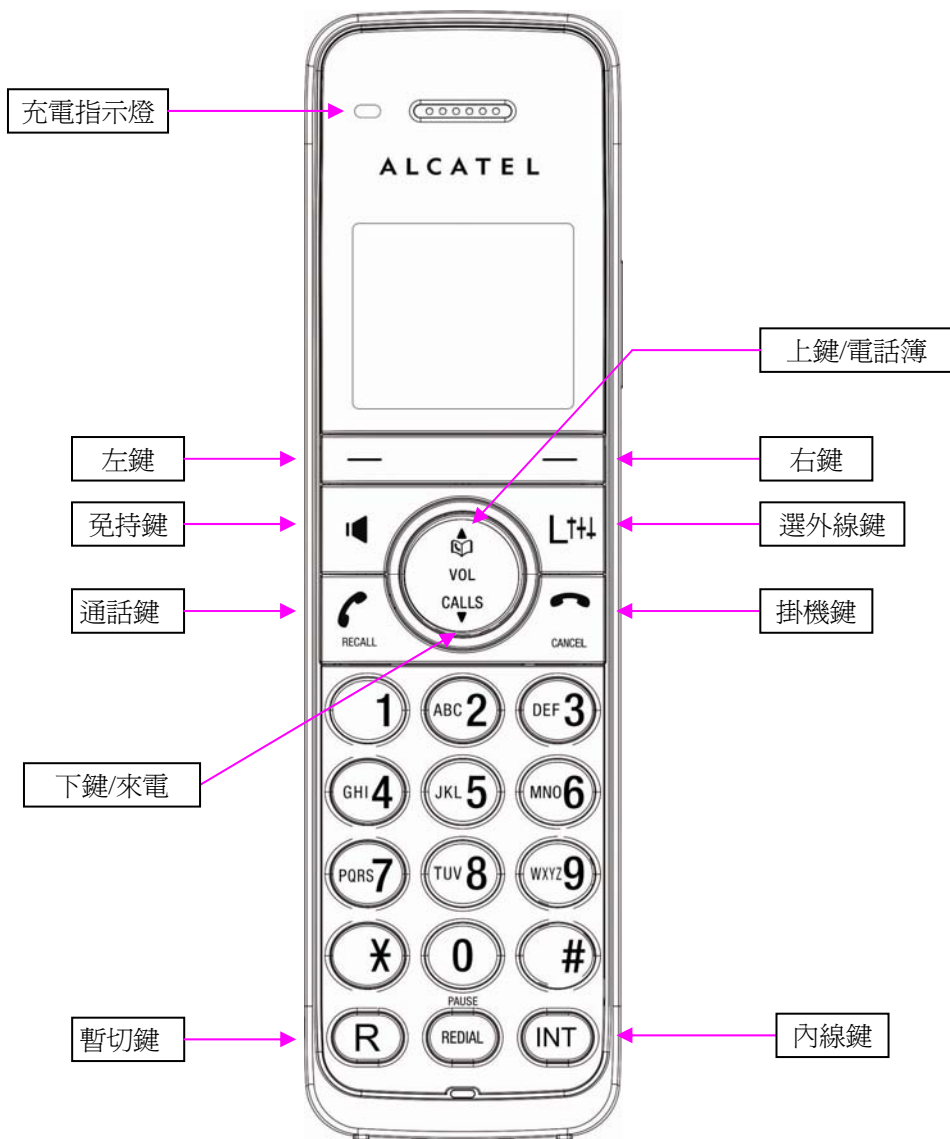

符號	功能說明
	天線
	通話中
	免持功能
	未接來電
	內線通話
	請勿打擾(鈴聲關閉)
	鬧鐘
	按鍵鎖
	電池電量
	選單
	確認
	回上一頁
	刪除
	麥克風靜音
	麥克風通話

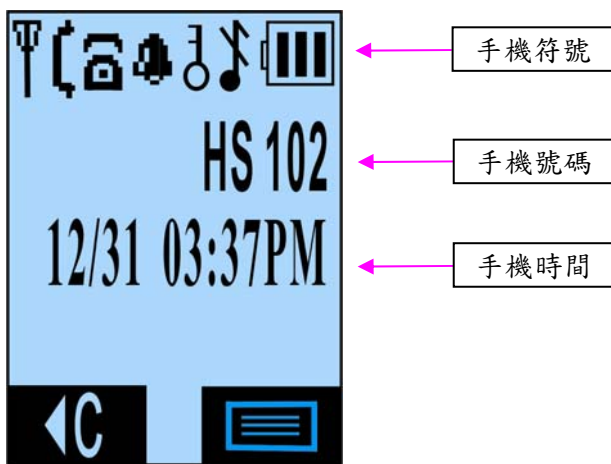





## 待機模式

在待機模式時，液晶螢幕上會顯示手機的號碼，同時電池圖示  及天線圖示  也會開啟。



## 接聽來電

當電話鈴響時，液晶螢幕上顯示 CALLING。如果您有使用來電顯示功能，液晶螢幕上將會有來電顯示，並在第一聲鈴聲之後顯示來電者的資訊。

1. 按通話鍵  接聽來電。通話圖示  將會顯示。當您按通話鍵時，通話計時器將會開始計時。
2. 開始通話。
3. 若要結束通話，請按掛機鍵 。



## 撥打電話

### 一般撥號

1. 按通話鍵  並稍候直到聽到撥號音。
2. 輸入電話號碼，液晶螢幕將會顯示您輸入的號碼。
3. 若要結束通話，請按掛機鍵 。



### 預先撥號

本電話可讓您先輸入電話號碼，並且在撥出之前先檢查液晶螢幕上的號碼是否正確。

1. 輸入電話號碼，液晶螢幕將會顯示您輸入的號碼。
2. 如果您要修改號碼，請按左鍵  以逐一刪除數字。或按掛機鍵  以刪除所有數字並返回待機模式。
3. 按通話鍵  撥出電話。



## 通話時

**通話計時器：**當您按通話鍵  時，通話計時器將會開始計時。

**調整手機音量：**在通話時，按上鍵  或下鍵  以調整音量。液晶螢幕將顯示目前的音量。聽筒的音量從小至大共四段音量。

### 接聽插播電話

在與外線通話時，如果您有第二位來電時，本電話將會在您與第一位來電者通話中，插播短嗶聲以通知您有第二位來電者。注意：插接音必須開啟才會聽到短嗶聲，如何開啟請參考本手冊第 16 頁說明。

1. 當您聽到「話中插播音」並且希望接聽時，請先按掛機鍵  掛斷原來通話電話。
2. 此時電話會再次響鈴，按通話鍵  接聽新的來電，開始通話。
3. 按掛機鍵  即可結束通話。

## 重撥功能

本電話可記憶您撥打的最後 30 通電話號碼。

按上鍵▲以進入選單，然後，按上鍵▲或下鍵▼以找出您要重撥的電話號碼，當電話號碼顯示出來時，按通話鍵☎撥出該電話號碼。

## 撥打內線電話

1. 當手機處於待機模式時，按 INT 鍵。INT 圖示 ☎ 將會顯示，您將會聽到內線電話撥號聲。
2. 輸入欲撥打的內線手機的號碼。
3. 在通話中的任一方手機上按掛機鍵📞即可結束內線通話。

## 接聽內線電話

1. 當接到內線電話來電時，接收方的手機將會發出呼叫鈴聲。INT 圖示 ☎ 將會閃爍，並且在液晶螢幕上顯示來電者的手機號碼。
2. 按通話鍵☎接聽內線來電。
3. 按掛機鍵📞結束內線通話。

## 在使用內線電話時接聽外線電話

1. 當接到外線電話來電時，正在進行內線通話的兩支手機都會發出一連串的短嗶聲。  
注意：插接音必須開啟才會聽到短嗶聲，如何開啟請參考本手冊第 16 頁說明。
2. 按掛機鍵📞結束內線通話，此時外線鈴聲會響。
3. 再按通話鍵☎接聽外線來電。先接聽的手機將會接下此通來電。
4. 若要結束通話，請按掛機鍵📞。

## 在與外線通話時撥打內線電話

### 與內線通話

1. 在與外線通話時，按 INT 鍵可暫時保留外線電話。
2. 輸入想轉接的內線手機號碼，以撥打內線電話。
3. 在您要結束內線通話時，按 INT 鍵以返回外線通話。



### 轉接外線電話

1. 在與外線通話時，按 INT 鍵可暫時保留外線電話。
2. 輸入接收方的手機號碼。
3. 連接上接收方的手機之後，按掛機鍵📞以轉接來電。或按 INT 鍵以返回與外線的通話。

### 三方通話

1. 在與外線通話時，按 INT 鍵可暫時保留外線電話。
2. 輸入接收方的手機號碼。
3. 當接收方的手機接聽後，原通話手機按“#”鍵可以進行三方通話。
4. 若要結束三方通話，請按掛機鍵📞。









## 免持功能

在通話時，按一下免持鍵 。免持圖示  將會顯示。您可以將手機放在一定距離範圍內並進行免持通話。若要結束通話，請按掛機鍵 。









## 電話簿操作

電話簿可讓您瀏覽聯絡人名單以找出您要撥打的電話號碼。您最多可以在記憶體中儲存 30 筆資料。

### 瀏覽電話簿資料

1. 按右鍵  以進入選單。
2. 按上鍵  或下鍵  選擇“電話簿”。
3. 按右鍵  液晶螢幕上將會顯示“查看”。
4. 按右鍵  液晶螢幕上將會顯示第一筆資料，(如果沒有資料，則會顯示無記錄)，按上鍵  或下鍵  以瀏覽資料。
5. 重複按左鍵  以返回待機模式。

### 儲存電話簿資料(新增聯絡人)









1. 在進入電話簿選單之後，按上鍵  或下鍵  以選擇“新增聯絡人”選項。
2. 按右鍵  確認，液晶螢幕將會提示“輸入姓名”。使用電話鍵盤按鈕輸入姓名，目前只能輸入英文名字。(按左鍵  可刪除輸入錯誤的字)
3. 輸入完姓名之後，按右鍵  確認。液晶螢幕上將會提示“電話號碼”。使用電話鍵盤按鈕輸入電話號碼。(按左鍵  可刪除輸入錯誤的字)
4. 輸入完電話號碼之後，按右鍵  完成新增聯絡人。
5. 重複按左鍵  以返回待機模式，或按掛機鍵  離開。

依照步驟 1 至 5 操作以儲存更多資料。您最多可以儲存 30 筆資料。如果通訊錄已無記憶體可用，液晶螢幕會顯示已滿。















### 電話按鍵相對應字元(按\*鍵切換大小寫字型)

Digit	1st Press	2nd Press	3rd Press	4th Press		1st Press	2nd Press	3rd Press	4th Press
1	*	+	,	-	.	1			
2	A	B	C	2		a	b	c	2
3	D	E	F	3		d	e	f	3
4	G	H	I	4		g	h	i	4
5	J	K	L	5		j	k	l	5
6	M	N	O	6		m	n	o	6
7	P	Q	R	S	7	p	q	r	s
8	T	U	V	8		t	u	v	8
9	W	X	Y	Z	9	w	x	y	z
0	Space	0							













## 從電話簿撥打電話

1. 按右鍵  以進入選單。
2. 按上鍵  或下鍵  以進入電話簿選單。
3. 按右鍵  確認。液晶螢幕將顯示“查看”。
4. 按右鍵  檢視資料，按上鍵  或下鍵  檢視資料，選取想要通話的電話號碼資料。
5. 按通話鍵  撥出螢幕上顯示的電話號碼。

## 編輯電話簿中現有的電話號碼

1. 按右鍵  以進入選單。
2. 再按上鍵  / 下鍵  以選擇電話簿，按右鍵  確認。
3. 再按上鍵  / 下鍵  以選擇“查看”選項。按右鍵  確認。
4. 按上鍵  / 下鍵  找出您要編輯的資料。
5. 當該筆資料顯示出來時，按右鍵  確認。液晶螢幕上將會顯示“1：刪除 2：編輯”。
6. 按數字鍵 2  可逐字刪除或增加數字。
7. 手機依序會要求“輸入姓名”、“電話號碼”，再按右鍵  確認鍵。
8. 重複按左鍵  以返回待機模式，或按掛機鍵  離開。

## 刪除電話簿中的單筆資料

1. 按右鍵  進入選單。
2. 再按上鍵  / 下鍵  以選擇電話簿，按右鍵  確認。
3. 再按上鍵  / 下鍵  以選擇“查看”選項，按右鍵  確認。
4. 按上鍵  / 下鍵  找出您要刪除的資料，按右鍵  確認。
5. 按數字鍵 1  刪除，螢幕顯示再確認一次。
6. 重複按左鍵  以返回待機模式，或按掛機鍵  離開。

## 來電顯示功能

本電話可在您接聽來電之前，顯示來電者的電話號碼。它會將來電的日期與時間記錄在記憶體。(如果您當地的電話公司可提供來電者的姓名，液晶螢幕上將會顯示來電者的姓名而非電話號碼。)

重要事項：您必須向當地電話公司申請使用「來電顯示」服務，才能使用此功能。





### 當有來電時檢視來電者的資訊

當有來電時，會在第一聲鈴聲響起之後，自動顯示來電者的姓名及/或電話號碼。





如果無法取得來電者的姓名，則會顯示來電者的電話號碼。

如果無法取得來電者的資訊，則不會顯示任何資訊。此時只有來電振鈴聲，此通來電的資料將不會儲存於記憶體中。

## 檢視來電記錄

1. 按右鍵  以進入選單。
2. 按上鍵▲/下鍵▼以選擇“來電記錄”選項，按右鍵  確認。
3. 所有尚未檢視(新)的來電會先顯示出來。如果沒有資料，液晶螢幕將顯示“全空”。
4. 按上鍵▲/下鍵▼檢視資料。
5. 重複按左鍵  以返回待機模式，或按掛機鍵  返回待機模式。



## 從來電者清單撥打電話

1. 按右鍵  以進入選單。
2. 按上鍵▲/下鍵▼以選擇“來電記錄”選項。
3. 按右鍵  以顯示來電者清單。
4. 按上鍵▲/下鍵▼找出您要回撥的來電者。
5. 當該筆資料顯示出來時，按通話鍵 ，以撥打該號碼，或重複按左鍵  以返回待機模式。







在座機記憶體中儲存來電記錄 30 筆資料，去電記錄 30 筆資料。

## 註冊登錄

手機註冊登錄在座機上後，手機號碼會顯示在手機液晶螢幕的右方。手機註冊登錄方法如下：





1. 按右鍵  以進入選單。
2. 按上鍵▲/下鍵▼以選擇“話機設定”選項。
3. 按右鍵  確認，液晶螢幕上將會顯示“話機註冊”。
4. 先按住座機基座上的註冊鍵約 10 秒鐘，直到註冊指示燈號恒亮為止。
5. 手機在“話機註冊”選項時，按右鍵  確認。液晶螢幕上將會顯示“PIN”。
6. 輸入密碼“0000”(出廠預設值)，經過 5~10 秒之後，手機號碼將顯示在液晶螢幕上右邊，表示手機註冊登錄已經完成。
7. 如果手機液晶螢幕顯示？，則表示登錄失敗。
8. 若要註冊登錄其他手機，請依照步驟 1~6 進行。

## 刪除手機



1. 按右鍵  以進入選單。
2. 按上鍵▲/下鍵▼以選擇“主機設定”選項。按右鍵  確認。
3. 液晶螢幕上將會顯示“刪除註冊”選項。
4. 按右鍵  確認。
5. 手機液晶螢幕顯示“刪除註冊--->101”(各主機顯示會有不同)。
6. 按上鍵▲/下鍵▼以選擇您要刪除的手機號碼(101~115)(會因座機種類不同而有不同數量的手機號碼)。
7. 按右鍵  確認。液晶螢幕上將會回到刪除註冊。
8. 重複按左鍵  以返回待機模式，或按掛機鍵 ，返回待機模式。

## 選擇外線撥出電話功能使用說明

選擇外線操作方法：手機在待機狀態下

1. 選第一線：手機按'L'鍵再按數字'1'(手機畫面會顯示 Line 1)，再按通話鍵，輸入電話號碼。
2. 選第二線：手機按'L'鍵再按數字'2'(手機畫面會顯示 Line 2)，再按通話鍵，輸入電話號碼。
3. 選第三線：手機按'L'鍵再按數字'3'(手機畫面會顯示 Line 3)，再按通話鍵，輸入電話號碼。
3. 選第四線：手機按'L'鍵再按數字'4'(手機畫面會顯示 Line 4)，再按通話鍵，輸入電話號碼。















例如：選擇第二線撥出電話號碼 0968-123456

手機在待機狀態時，手機按'L'鍵，再按數字鍵'2'(手機畫面會顯示 Line 2)，再按通話鍵，輸入電話號碼 0968123456，即可使用第二線通話，通話結束時按掛機鍵掛斷電話。















## 手機功能設定

### 手機鈴聲設定













設定外線鈴聲類型及音量

1. 按右鍵以進入選單。
2. 按上鍵/下鍵以選擇“話機設定”選項。按右鍵確認。
3. 液晶螢幕上將會顯示“話機註冊”。
4. 按上鍵/下鍵以選擇“外線鈴聲”選項。按右鍵確認。
5. 按上鍵/下鍵從 10 種鈴聲旋律中選擇一種。當您切換至每一種鈴聲時，都會播放一段鈴聲。
6. 按右鍵確認。液晶螢幕上將會顯示“音量”。
7. 按下鍵 (上鍵)以降低(放大) 鈴聲音量，按右鍵確認。
8. 重複按左鍵以返回待機模式，或按掛機鍵返回待機模式。













設定內線鈴聲類型及音量

1. 按右鍵以進入選單。
2. 按上鍵/下鍵以選擇“話機設定”選項。按右鍵確認。
3. 液晶螢幕上將會顯示“話機註冊”。
4. 按上鍵/下鍵以選擇“內線鈴聲”選項。按右鍵確認。
5. 按上鍵/下鍵從 10 種鈴聲旋律中選擇一種。當您切換至每一種鈴聲時，都會播放一段鈴聲。
6. 按右鍵確認。液晶螢幕上將會顯示“音量”。
7. 按下鍵 (上鍵)以降低(放大) 鈴聲音量，按右鍵確認。
8. 重複按左鍵以返回待機模式，或按掛機鍵返回待機模式

















### 手機語言設定

1. 按右鍵以進入選單。
2. 按上鍵/下鍵以選擇“話機設定”選項。按右鍵確認。
3. 液晶螢幕上將會顯示“話機註冊”。
4. 按上鍵/下鍵以選擇“語言設定”選項。按右鍵確認。
5. 按上鍵/下鍵選擇操作手機的語言目前有 8 國語言可選擇，分別是“繁體中文”“葡萄牙語”“荷蘭語”“西班牙語”“義大利語”“法國語”“德語”“英語”。
6. 按右鍵確認。
7. 重複按左鍵以返回待機模式，或按掛機鍵返回待機模式













## 手機對比設定

1. 按右鍵  以進入選單。
2. 按上鍵  / 下鍵  以選擇“話機設定”選項。按右鍵  確認。
3. 液晶螢幕上將會顯示“話機註冊”。
4. 按上鍵  / 下鍵  以選擇“對比”選項。
5. 按右鍵  確認。液晶螢幕上將會顯示“對比”。
6. 按上鍵  / 下鍵  調整明暗對比。按右鍵  確認。
7. 重複按左鍵  以返回待機模式，或按掛機鍵  返回待機模式。

## 手機鬧鐘設定













1. 按右鍵  以進入選單。
2. 按上鍵  / 下鍵  以選擇“話機設定”選項。按右鍵  確認。
3. 液晶螢幕上將會顯示“話機註冊”。
4. 按上鍵  / 下鍵  以選擇“鬧鐘”選項，按右鍵  確認。
5. 液晶螢幕上將會顯示“關閉”。
6. 按上鍵  / 下鍵  選擇“開啟”，按右鍵  確認。
7. 手機液晶螢幕上將會顯示鬧鐘符號  及目前設定的鬧鐘時間“12:00 \*AM”，輸入想設定的時間 (12 小時制)，其中上午及下午是使用 \* 字切換，設定完成後，按右鍵  確認。
8. 此時手機會響鈴及顯示“鈴聲 1”，按上鍵  / 下鍵  選擇想要的鈴聲，按右鍵  確認。
9. 重複按左鍵  以返回待機模式，或按掛機鍵  返回待機模式。

## 手機按鍵音設定

1. 按右鍵  以進入選單。
2. 按上鍵  / 下鍵  以選擇“話機設定”選項。按右鍵  確認。
3. 液晶螢幕上將會顯示“話機註冊”。
4. 按上鍵  / 下鍵  以選擇“按鍵音”選項，按右鍵  確認。
5. 液晶螢幕上將會顯示“開啟”。
6. 按上鍵  / 下鍵  選擇“開啟”或“關閉”按鍵音，按右鍵  確認。
7. 重複按左鍵  以返回待機模式，或按掛機鍵  返回待機模式。

## 手機自動應答設定

當手機在充電座充電時，如果自動應答是“關閉”則當有來電時，手機拿起需按通話鍵通話；如果自動應答是“開啟”則當有來電時，手機直接拿起來就可通話。

1. 按右鍵  以進入選單。
2. 按上鍵  / 下鍵  以選擇“話機設定”選項。按右鍵  確認。
3. 液晶螢幕上將會顯示“話機註冊”。
4. 按上鍵  / 下鍵  以選擇“自動應答”選項，按右鍵  確認。
5. 液晶螢幕上將會顯示“關閉”。
6. 按上鍵  / 下鍵  選擇“開啟”或“關閉”自動應答功能，按右鍵  確認。
7. 重複按左鍵  以返回待機模式，或按掛機鍵  返回待機模式。

## 手機按鍵鎖設定

1. 在待機模式下，長按 \* 鍵三秒以上將進入按鍵鎖功能，此時手機液晶螢幕右上角將會顯示按鍵鎖符號  。
2. 再長按 \* 鍵三秒以上將解除按鍵鎖功能。









## 手機 REDIAL 鍵功能說明

在待機狀態下，按 REDIAL 鍵會顯示最近一通撥出的電話號碼。按通話鍵  撥出此號碼。

## 手機 R 鍵功能說明













在待機狀態下，長按 R 鍵三秒以上，可以快速進入語言選擇。在通話中，按 R 鍵可接聽前級交換機的插播電話(此功能必需有向使用的電信局申請話中插播功能才会有作用)。

## 還原話機設定(恢復出廠設定值)









1. 按右鍵  以進入選單。
2. 按上鍵 /下鍵  以選擇“話機設定”選項。
3. 按右鍵  確認。
4. 按上鍵 /下鍵  以選擇“還原話機設定”選項，按右鍵  確認。
5. 液晶螢幕上將會顯示“ 確認? 1：確定 2：取消”。
6. 重複按左鍵  返回待機模式或按掛機鍵  離開。

## 座機功能設定

### 時間設定











1. 按右鍵  以進入選單。
2. 按上鍵 /下鍵  以選擇“主機設定”選項。
3. 按右鍵  確認。
4. 按上鍵 /下鍵  以選擇“時間設定”。
5. 按右鍵  確認。液晶螢幕將顯示 MM/DD/YYYY 及 DD/MM/YYYY 兩種 24 小時格式。
6. 按上鍵 /下鍵  選擇，按右鍵  確認，再依序輸入時間設定：月(日)、日(月)、年、時、分。如果輸入的數字不符合所要求的設定項目，將會發出長嗶聲。
7. 按右鍵  確認您的修改。
8. 重複按左鍵  返回待機模式或按掛機鍵  離開。

## 還原主機設定(恢復出廠設定值)

1. 按右鍵  以進入選單。
2. 按上鍵 /下鍵  以選擇“主機設定”選項。
3. 按右鍵  確認。
4. 按上鍵 /下鍵  以選擇“還原主機設定”選項，按右鍵  確認。
5. 液晶螢幕上將會顯示“ 確認? 1：確定 2：取消”。
6. 重複按左鍵  返回待機模式或按掛機鍵  離開。

## 插接音

當外線來電呼叫使用中的手機時，座機會送出嘟嘟短促音通知正在通話中的手機，本功能可提供開啟或關閉插接音。













1. 按右鍵  以進入選單。
2. 按上鍵 /下鍵  以選擇“主機設定”選項。按右鍵  確認。
3. 按上鍵 /下鍵  以選擇“插接音”選項。按右鍵  確認。
4. 液晶螢幕將顯示“關閉”。表示插接音關閉，按上鍵 /下鍵  以選擇開啟或關閉插接音。
5. 按右鍵  確認您的選擇。



6. 重複按左鍵  返回待機模式或按掛機鍵  離開。

## 語音提示功能(自動語音應答)

XPS-4010<sup>+</sup>使用內建語音提示功能，目前無法由使用者更改語音提示內容，如果要開啟(或關閉)語音提示功能，請依下列步驟操作。

1. 按右鍵  以進入選單。
  2. 按上鍵  / 下鍵  以選擇“主機設定”選項，按右鍵  確認。
  3. 按上鍵  / 下鍵  以選擇“自動語音應答”選項，按右鍵  確認。
  4. 手機螢幕會先顯示“請稍候”，再顯示“開啟”。
  5. 按上鍵  / 下鍵  以選擇“開啟”或“關閉”選項，按右鍵  確認。
  6. 重複按左鍵  返回待機模式或按掛機鍵  離開。
- 設定完成“自動語音應答”開啟或關閉後，請將主機電源重開一次，完成設定。

注意：如果選擇關閉自動語音應答，則任何外線來電，所有的手機都會響鈴，也都可以接這通來電。

## 手機選單架構

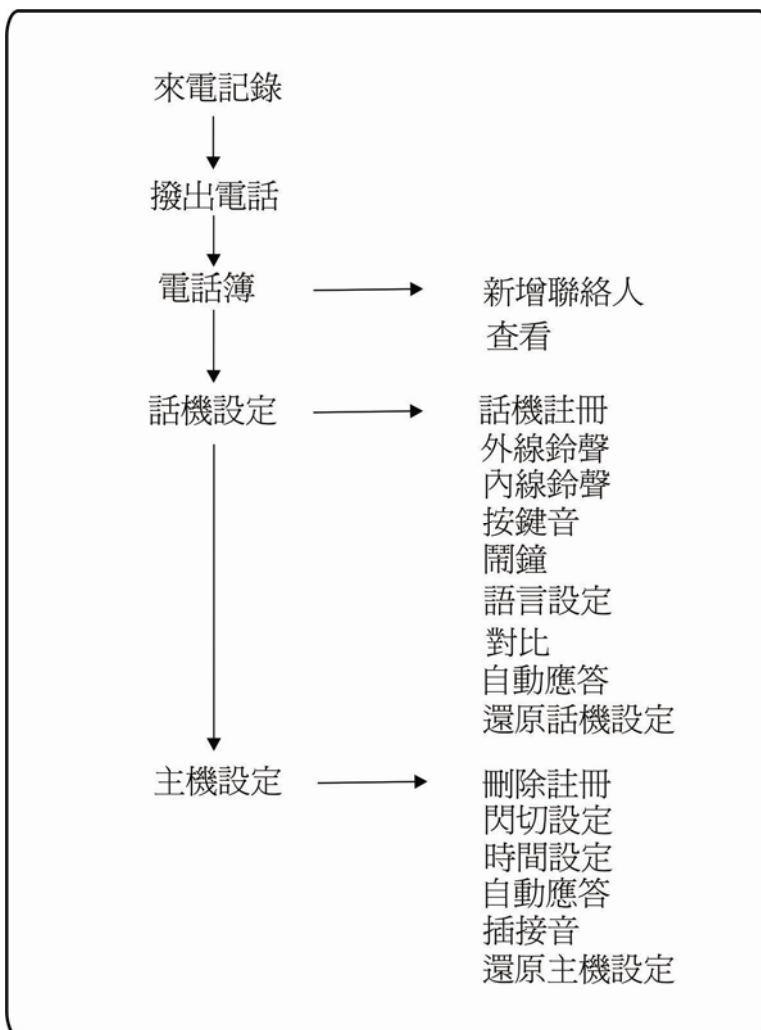

## 疑難排解指南

問題	解決方法
電話無法使用	<ul style="list-style-type: none"> <li>● 確認座機的電源線已插入插座。</li> <li>● 檢查電池是否已完全充電並正確安裝。</li> <li>● 確認電話線是否已經插入電話插孔。</li> <li>● 確認手機已註冊至座機。</li> </ul>
無撥號音	<ul style="list-style-type: none"> <li>● 確認座機的電源線已插入插座。</li> <li>● 確認電話線插頭是否已經插入電話插孔及電話線。</li> </ul>
來電顯示功能不正常	<ul style="list-style-type: none"> <li>● 請洽詢您當地的電話公司。</li> <li>● 在接聽電話之前，讓電話鈴響至少一次。</li> <li>● 如果對方把來電顯示功能取消，液晶螢幕上將不會顯示電話號碼。</li> </ul>
無法回覆來電通話	<ul style="list-style-type: none"> <li>● 請設定正確的回撥設定值。</li> </ul>
在手機充完電之後不久就出現電力用盡的圖示	<ul style="list-style-type: none"> <li>● 更換新的電池</li> </ul>
無法轉接電話	<ul style="list-style-type: none"> <li>● 確認您輸入的是正確的手機號碼。</li> <li>● 確認目標手機已登錄至同一部座機。</li> </ul>
主機外線指示燈閃爍	<ul style="list-style-type: none"> <li>● 主機背面外線插孔 1,2,3 及 4 請確實插入電信局外線，主機接上電源開機時會自動偵測外線，如果主機正面的外線指示燈閃爍，表示該條外線沒有接好或電話線有問題，請重新插拔該條外線並請重開(插拔)主機電源，直到所有外線指示燈在熄滅狀態下。</li> </ul>

## 主要功能特點

- 1.8GHz 數位式無線技術，支援 GAP 協議
- 具有四個外線 15 個內線小總機及基地台功能
- 提供四個空中通話頻道供四支手機同時使用
- 有自動總機應答功能
- 手機內線通話
- 外線來電轉接其它手機
- 來電顯示
- LCD 點陣式顯示螢幕
- 可儲存 60 筆電話號碼
- 可記錄來電 30 筆
- 可記錄去電 30 筆
- 手機免持對講
- 可調整手機聽筒音量和振鈴音量
- 多國語言可選擇(8 國語言)
- 摘機撥號及預撥號功能
- 通話時間顯示
- 弱訊號警示音
- 低電池警示音
- 有按鍵鎖功能
- 鬧鐘功能
- 手機螢幕保護時鐘顯示

## 技術規格

頻率範圍	臺灣 1880~1895MHz
調變方式	GFSK
多工通訊	TDMA/TDD
通道頻寬	1.728MHz
載波頻率偏移	< ±50 KHz
輸出功率	最大 250mW ；平均 10mW
充電時間	12 小時
環境溫度	正常:15°C~35°C ，特殊: 0°C~40°C
濕度	0%~90%
尺寸(毫米)	座機:210x183x50 ； 手機:160x46x22
電源供應	座機輸入: DC9V 0.5A 手機充電座輸入: DC7V 0.42A 手機輸入: 鎳氫 1.2Vx2, 600mA





設計和規格如有更改，恕不另行通知。

## TABEL OF CONTENTS

<b>PACKAGE CONTENTS</b> .....	22
<b>GETTING STARTED</b> .....	22
<b>SAFETY PRECAUTIONS</b> .....	23
<b>INSTALLING THE BASE</b> .....	23
<b>THE BASE</b> : Features and Functions.....	24
<b>THE HANDSET</b> .....	25
Handset LCD & Key Pad.....	26
<b>STANDBY MODE</b> .....	27
<b>RECEIVING A CALL</b> .....	27
<b>MAKING A CALL</b> .....	27
<b>DURING A CALL</b> .....	27
Call Timer.....	27
Adjusting the Volume.....	27
Call Waiting.....	27
Redial.....	28
Calling an Internal Number.....	28
Receiving an Internal Call.....	28
Receiving an External Call during an Internal Call.....	28
Calling an Internal Number during an External Call.....	28
<b>SPEAKERPHONE</b> .....	29
<b>PHONEBOOK</b> .....	29
Browsing the Phonebook.....	29
Saving a Phonebook.....	29
Alphanumeric Keys.....	30
Calling from the Phonebook.....	30
Editing the Phonebook.....	30
Deleting the Phonebook.....	30
<b>CALLER ID</b> .....	31
Information Displayed during an Incoming Call.....	31
View the Incoming Call List.....	31
Calling from the Incoming Call List.....	31
<b>REGISTERING A HANDSET</b> .....	32
<b>DELETE A HANDSET</b> .....	32
<b>LINE SELECT FUNCTION</b> .....	32
<b>HANDSET SETTINGS</b> .....	33
Handset Ringer Melody Settings.....	33
Setting the Ringer Melody and Volume for External Calls.....	33
Setting the Ringer Melody and Volume for Internal Calls.....	33

Handset Language Setting.....	33
Handset Contrast Setting.....	33
Handset Alarm Setting.....	34
Handset Key Tone Setting.....	34
Handset Auto Answer Setting.....	34
Keypad Lock.....	34
Handset REDIAL Key Function.....	35
Handset R Key Function.....	35
Restoring Handset to Factory Default.....	35
<b>BASE STATION SETTING</b> .....	35
<hr/>	
Time and Date Setting.....	35
Restoring Base to Factory Default.....	35
Call Waiting Tone.....	36
Voice Announce Function.....	36
Handset Menu.....	37
<b>TROUBLE SHOOTING</b> .....	38
<hr/>	
<b>FEATURES</b> .....	39
<hr/>	
<b>TECHNICAL SPECIFICATIONS</b> .....	39
<hr/>	

## PACKAGE CONTENTS

<p>1 Base</p> 	<p>4 Handsets</p> 
<p>4 Chargers</p> 	<p>4 Handset Rechargeable Battery Packs. (2 Ni-MH batteries per pack)</p> 
<p>5 Adapters (1 for base, 4 for handsets) Specifications: Base – DC9V, 0.5A Handset – DC7V, 0.42A</p> 	<p>4 Telephone Cables</p> 
<p>1 Certificate of Guarantee</p> 	<p>1 User's Guide</p> 

## GETTING STARTED

1. Carefully unpack your wireless handset. If the product is damaged, do not operate it. Return the product to the seller.
2. Make sure you have all the package contents, including handsets, chargers, adapters, batteries, phone cables, belt clip, and the user's guide.
3. Plug one end of the adapter into the power slot on the back of the charger.
4. Plug the other end of the adapter into an AC outlet.  
Use a 9V DC, 500mA power supply for the base and handsets adapter.
5. To prevent possible interference, it is recommended that you do not place this product next to other digital devices.

## **SAFETY PRECAUTIONS**

- Make sure your handset for XPS-4010<sup>+</sup> is fully charged before first use. The charging cradle is connected to the AC outlet through the AC adapter.
- To operate properly, both the handset charging cradle and the XPS-4010<sup>+</sup> host must connect to an AC adapter. During power outage, the wireless part will not work, you have to connect to a wired telephone with an external line or purchase an UPS uninterruptible power system as backup.
- Only use the supplied rechargeable Ni-MH batteries for the handset. The use of other battery types or non-rechargeable batteries cells can be dangerous. These may cause interference and/or unit damages.
- It is normal for the battery to become hot gradually during the charging process. It will not pose any dangerous.
- Do not let the charging cradle close to metal or wet area.
- Dispose of batteries safely. Do not burn them or put them together with the general household waste, they must be placed in the appropriate recycling station.
- Do not expose the batteries to direct sunlight or extreme cold environment. Do not put the batteries close to a heating source such as radiators, cookers, etc.

## **INSTALLING THE BASE**

1. Plug one end of the power cable into the DC9V slot on the back of the base, and the other end into a power outlet.
2. Plug the PSTN line into the RJ-11 jacks labeled L1, L2, L3 and L4 on the base.
3. Register each handset on the XPS-4010<sup>+</sup> base (the handsets included in the package have been registered). Once registered, you can use the wireless handsets within the signal range of the base.
4. The transmission power of this device is very low. Extended period of use does not cause health hazard. To maximize the transmission distance, it is recommended that you place the base in a central location of the house that is not blocked by any obstacles. For example, in a three story house, it is recommended to place the base on the second floor, in an obstacle free environment. Do not place the base close to obstacles or possible sources of interference such as metallic substances, metal cases, or walls. You can place the base inside a wooden cabinet, glass cabinet, or on the ceiling, but not inside a metal cabinet, or in any space blocked by metal.

## THE BASE

### Features and Functions

1. Serves as the base station for 4 external lines and 15 internal lines.
2. Provides 4 channels for simultaneous use by 4 handsets.
3. Voice announce function (DISA).
4. Digital wireless handsets that provide superior voice quality, no interference, and privacy protection.
5. Power supply: 9VDC input, with 110V~ 220V AC 50~60Hz adapter.
6. Weight: 410g
7. Dimensions: 210x183x50mm

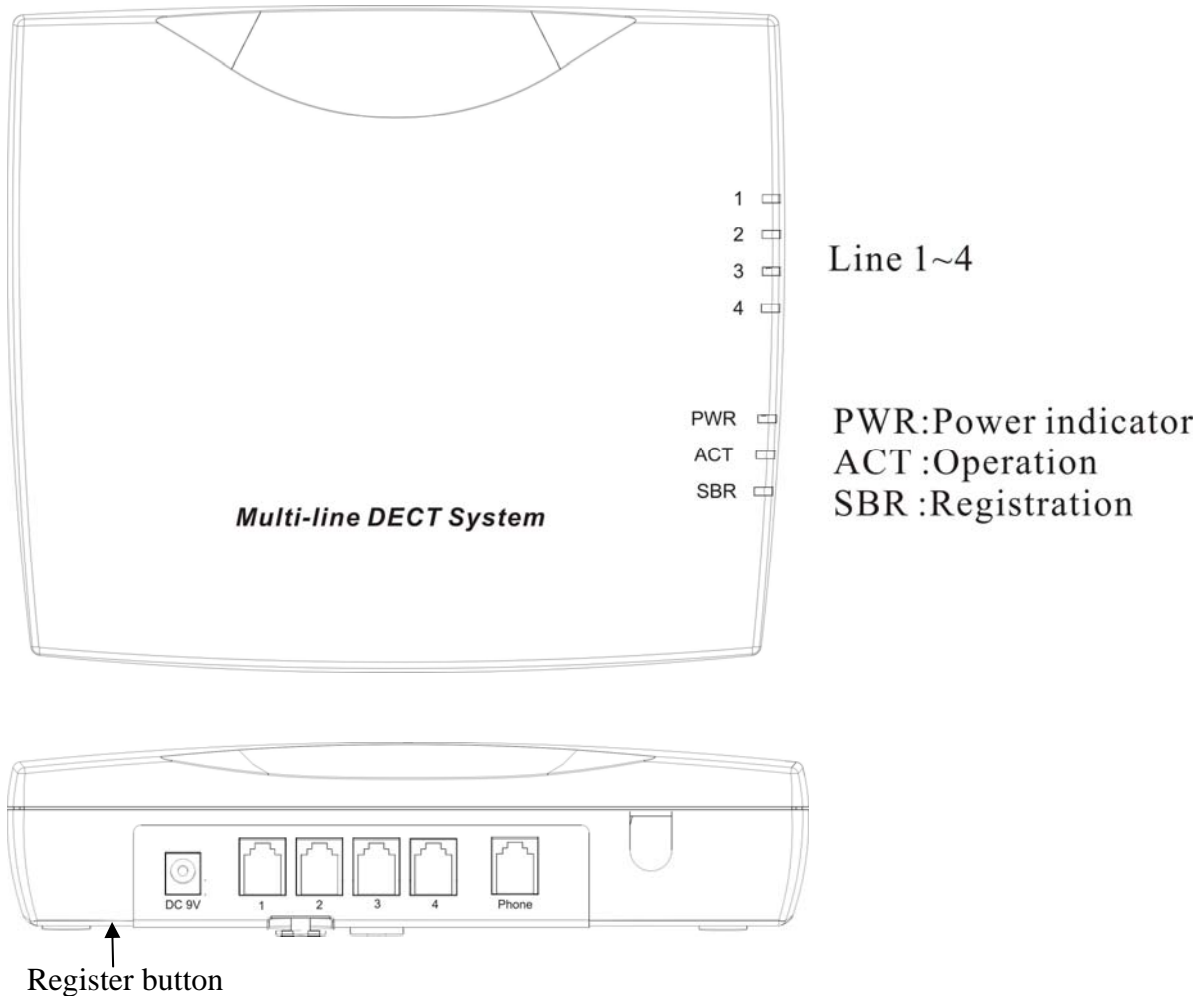

Line 1~4 LED will lit while in use.

UT-400D<sup>+</sup> has phone line detect function. It will detect the phone line when the base power on. In standby mode Line 1~4 LED will off. Line LED sparkled means that the base did not detect the phone line. Please plug the PSTN phone line once again.



## THE HANDSET

1. Power supply: 7VDC input, with 100V ~ 240V AC 50~60Hz adapter.
2. Uses two rechargeable AAA Ni-MH 1.2V batteries.
3. Weight: 140g .
4. Dimensions: (L x W x H): 169mm x 48mm x 23mm.

### Handset Charger

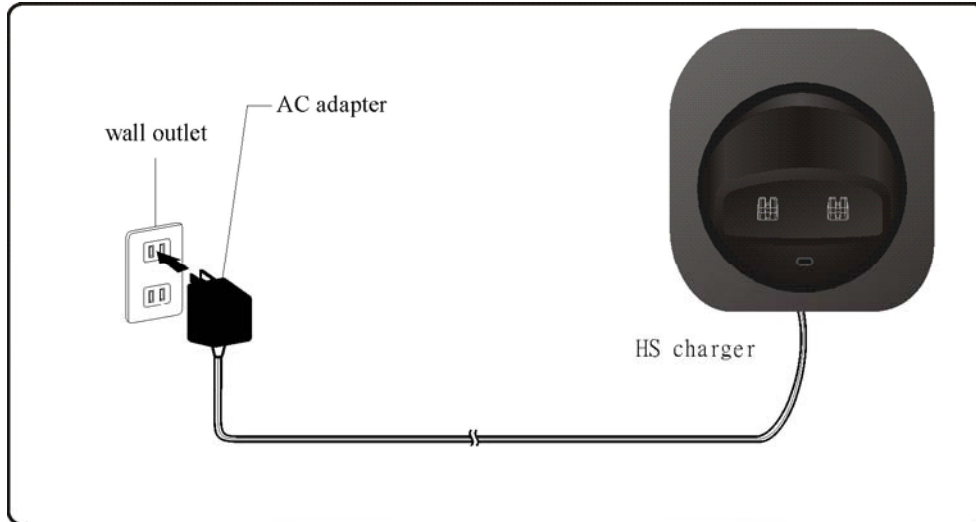

### Handset Battery Cover

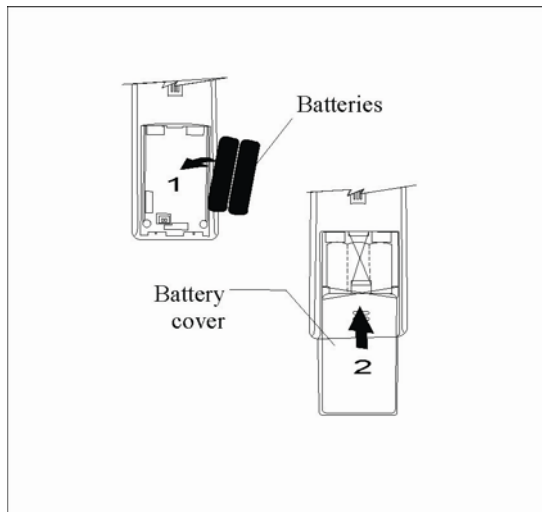

1. Insert the batteries, observe the correct direction.
2. Slide the battery cover up into place.

#### **Important:**

Charge for 12 hours before using for the first time.

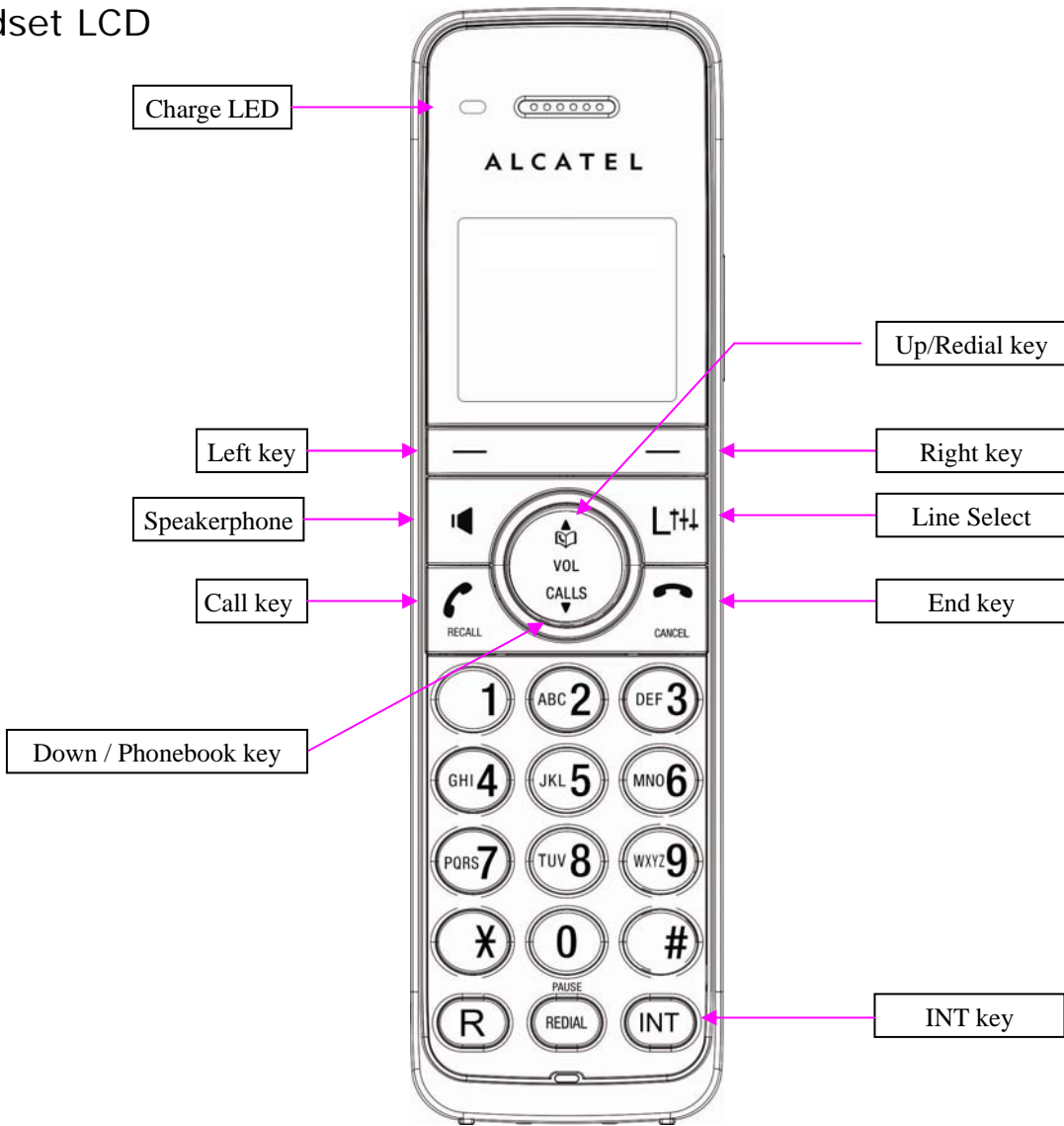

# Handset LCD

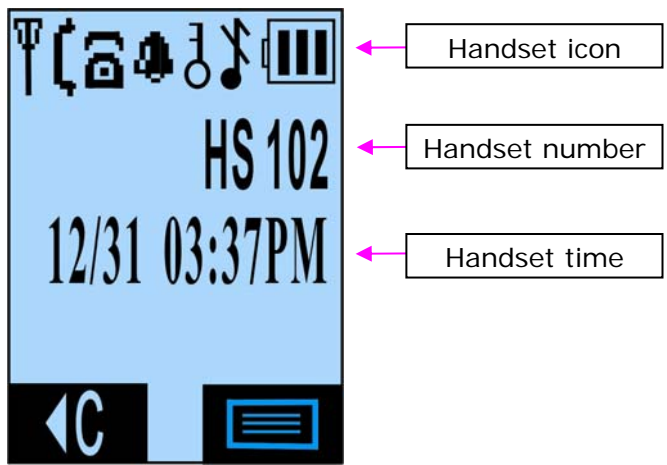

Icon	Function
	Antenna
	In talk mode
	Speakerphone
	Miss call
	Internal call
	Non-disturb (Ringer off)
	Alarm
	Keypad lock
	Battery
	Menu
	OK
	Back
	Delete
	Mic mute
	Mic ON







## STANDBY MODE

In standby mode, the handset phone number, battery level , and signal strength  are displayed.



## RECEIVING A CALL

When the handset rings, if the caller ID function is activated, caller information is displayed after the first ring.

1. Press call key  to receive the call. The call in progress symbol  is displayed. When you press call key , the call timer is started.
2. The call begins.
3. Press end key  to end the call.



## MAKING A CALL

### Standard Dialing

1. Press call key , and wait for the dial tone.
2. Enter the recipient phone number. The number is displayed.
3. Press end key  to end the call.

### Preview Dialing

You can enter the phone number first, and check if it is correct before dialing.



1. Enter the recipient phone number. The number is displayed.
2. To edit the phone number, press left  key to erase. To erase all numbers and return to standby mode, press end key .
3. Press call key  to make the call.

## DURING A CALL

### Call Timer



When you press call key , the call timer is started.

### Adjusting the Volume

During a call, press up /down  key to adjust among the 4 volume levels. The current volume is displayed.

### Call Waiting

During an external call, a second incoming call is indicated by a short beep. (The call waiting tone function must be ON)



1. When you hear the call waiting tone, if you want to take this incoming call, press end key  to end the call.
2. The handset will ring, press call key  to receive this new incoming call.
3. Press end key  to end the call.

## Redial



The thirty most recently dialled numbers are saved to your handset.

1. Press up key▲ to enter the menu.
2. Press up key▲/down key▼ to select the number you wish to redial, and press call key  to dial the number.





## Calling an Internal Number

1. In the standby mode, press INT key. INT symbol  will be displayed, and you will hear the internal line dial tone.
2. Enter the handset number of the internal line you wish to call.
3. To end the call, press end key  on either one of the handsets.

## Receiving an Internal Call

1. During an incoming internal call, the receiving handset will begin to ring. INT symbol  flashes, and the caller's handset number is displayed.
2. Press call key  to receive the call.
3. Press end key  to end the call.

## Receiving an External Call during an Internal Call

1. During an incoming external call, both handsets in the call will beep. The Call waiting tone function must be ON. Please refers to P.36 for setting the Call Waiting Tone.
2. Press end key  to end the internal call.
3. Press call key  to receive the call. The handset that presses call key  first will be the receiver of the call.
4. Press end key  to end the call.

## Calling an Internal Number during an External Call

### Calling an Internal Number

1. During an external call, press INT key to hold the call.
2. Enter the handset number of the internal line you wish to call.
3. Press INT key again to end the internal call and return to the external call.



### Transferring an External Call

1. During an external call, press INT key to hold the call.
2. Enter the handset number of the internal line you wish to transfer the call to.
3. Once the line is connected, press end key  to transfer the call, or press INT key to return to the external call.

### Conference Call

1. During an external call, press INT key to hold the call.
2. Enter the handset number of the internal line you wish to transfer the call to.
3. Once the line is connected, press "#" key to conference call.
4. Press end key  to end the conference call.









## SPEAKERPHONE

1. During the call, press the speakerphone key . Speakerphone symbol  is displayed.
2. You can place the handset within hearing range and continue the call.
3. Press end key  to end the call.









## PHONEBOOK

You can browse the Phonebook to find the number you wish to call. You can save a maximum of thirty contacts.

### Browsing the Phonebook

1. Press right key  to enter the menu.
2. Press up /down  key to select **Phone Book**.
3. Press right key . **View Entry** is displayed.
4. Press right key  to display the first contact. (If no contacts have been entered, **EMPTY** is displayed.) Press up /down  key to view contact information.
5. Press left key  repeatedly to return to the standby mode.

### Saving a Phonebook





1. In the contacts list menu, press up /down  key to select **Add Entry**.
2. Press right key  to confirm. **Enter Name :** is displayed. Use the keypad to enter the name of the new contact. The supported language is English. (Press left key  to delete an incorrect character.)
3. Press right key  to confirm. **Enter No :** is displayed. Use the keypad to enter the phone number of the new contact. (Press left key  to delete an incorrect character.)
4. Press right key  to confirm.
5. Press left key  repeatedly to return to the standby mode, or press end key  to exit.

Repeat steps 1 to 5 to save more contacts. You can save a maximum of 30 contacts. If the memory is full, **BookFull** will be displayed.









## Alphanumeric Keys (press \* to switch between upper case and lower case)

Digit	1st Press	2nd Press	3rd Press	4th Press		1st Press	2nd Press	3rd Press	4th Press
1	*	+	,	-	.	1			
2	A	B	C	2		a	b	c	2
3	D	E	F	3		d	e	f	3
4	G	H	I	4		g	h	i	4
5	J	K	L	5		j	k	L	5
6	M	N	O	6		m	n	O	6
7	P	Q	R	S	7	p	q	r	s
8	T	U	V	8		t	u	v	8
9	W	X	Y	Z	9	w	x	y	z
0	Space	0							







### Calling from the Phonebook

1. Press right key  to enter the main menu.
2. Press up▲/down▼ key to select **Phonebook**.
3. Press right key  to confirm. **View Entry** is displayed.
4. Press right key  to view contact information, and press up▲/down▼ key to select the desired contact.
5. Press call key  to make a call to the phone number displayed.

### Editing the Phonebook

1. Press right key  to enter the menu.
2. Press up▲/down▼ key to select **Phonebook**, and press right key  to confirm.
3. Press up▲/down▼ key to select **View Entry**.
4. Press right key  to confirm.
5. Press up▲/down▼ key to select the phone book you wish to edit.
6. When the contact information is displayed, press right key . **1: Del 2: Edit** is displayed.
7. Press key number 2  to edit the name and number.
8. Handset will request to **Enter Name:** and **Enter No.:** respectively.
9. When finished, press right key  to confirm.
10. Press left key  repeatedly to return to the standby mode, or press end key  to exit.

### Deleting the Phonebook

1. Press right key  to enter the menu.
2. Press up▲/down▼ key to select **Phonebook**, and press right key  to confirm.
3. Press up▲/down▼ key to select **View Entry**, and press right key  to confirm.
4. Press up▲/down▼ key to select the contact you wish to delete, and press right key  to confirm.
5. Press key number 1  to delete the contact.
6. Press left key  repeatedly to return to the standby.

## CALLER ID

The handset allows you to view the caller's phone number before you accept a phone call. The time and date of the call are saved to the internal memory. (If your local phone service provides Caller ID with Name, the caller's name will be displayed instead of the number.)

**Important:** To activate this function, contact your local phone service provider for the Caller ID service.









### Information Displayed during an Incoming Call

For each incoming call, the caller's name and/or telephone number will be displayed after the first ring.









If the caller's name cannot be identified, the number will be displayed.

If the caller's information could not be obtained, the LCD display will be blank. Only the ring tone will sound, and the call will not be saved to the internal memory.

### Viewing the Incoming Call List

1. Press right key  to enter the menu.
2. Press up /down  key to select **In Call**.
3. Press right key  to view the incoming call list. New entries that have not been viewed will be displayed first. If there are no entries, **Empty** will be displayed.
4. Press up /down  key to view the caller information.
5. Press left key  repeatedly to return to the standby mode, or press end key  to exit.

### Calling from the Incoming Call List







1. Press right key  to enter the menu.
2. Press up /down  key to select **In Call**.
3. Press right key  to view the incoming call.
4. Press up /down  key to find the caller you wish to call.
5. When the contact information is displayed, press call key . or Press left key  repeatedly to return to the standby mode.

The internal memory stores 30 incoming calls and 30 outgoing calls.











## REGISTERING A HANDSET

Once a handset has been registered, the handset number will be displayed on the right of the LCD display.





### To register the handset:



1. Press right key  to enter the menu.
2. Press up /down  key to select **HS Setting**.
3. Press right key  to confirm. **Register HS** is displayed.
4. Press and hold the register button on the base, until the registration indicator lights up(>10s).
5. While **Register HS** is displayed, press right key  to confirm. Then enter the PIN code "0000" (default). , press right key  to confirm. **Please Wait** is displayed as the handset searches for the base.
6. After 5 to 10 seconds, the handset number will appear in the upper right corner of the LCD display. Registration is complete.
7. If **?** is displayed, it means registration was not successful.
8. To register the other handsets, follow steps 1 to 6.

## DELETE A HANDSET

1. Press right key  to enter the menu.
2. Press up /down  key to select **Base Setting**.
3. Press right key  to confirm. **Delete HS** will be displayed.
4. Press right key  to confirm.
5. **Delete HS → 101** is displayed.
6. Press up /down  key to select the handset number you would like to delete (for example, 101 to 115; the number of handset numbers may be different for each base).
7. Press right key  to confirm. **Delete HS** is displayed again.
8. Press left key  repeatedly to return to the standby mode, or press end key  to exit.

## LINE SELECT FUNCTION

1. Select line 1, use handset to press L key, press 1, (LCD display Line 1) then call key  and enter the phone number.
2. Select line 2, use handset to press L key, press 2, (LCD display Line 2) then call key  and enter the phone number.
3. Select line 3, use handset to press L key, press 3, (LCD display Line 3) then call key  and enter the phone number.
4. Select line 4, use handset to press L key, press 4, (LCD display Line 4) then call key  and enter the phone number.















example: In the standby mode, handset press L key, press 2 key(handset LCD display Line 2), press call key  and enter the phone number (0968123456), then you can use line 2 to talk, after conversation, press end key  to end the call.

















## HANDSET SETTINGS

### Handset Ringer Melody Settings













#### Setting the Ringer Melody and Volume for External Calls

1. Press right key  to enter the menu.
2. Press up /down  key to select **HS Setting**.
3. Press right key  to confirm. **Register HS** is displayed.
4. Press up /down  key to select **Melody EXT**. Press right key  to confirm.
5. Press up /down  key to select among 10 melodies. A short melody will be played while you switch to each ring tone.
6. Press right key  to confirm. **Volume** is displayed.
7. Press down key  to reduce the volume, or up key  to increase the volume. Press right key  to confirm.
8. Press left key  repeatedly to return to the standby mode, or press end key  to exit.







#### Setting the Ringer Melody and Volume for Internal Calls

1. Press right key  to enter the menu.
2. Press up /down  key to select **HS Setting**.
3. Press right key  to confirm. **Register HS** is displayed.
4. Press up /down  key to select **Melody INT**. Press right key  to confirm.
5. Press up /down  key to select among 10 melodies. A short melody will be played while you switch to each ring tone.
6. Press right key  to confirm. **Volume** is displayed.
7. Press down key  to reduce the volume, or up key  to increase the volume. Press right key  to confirm.
8. Press left key  repeatedly to return to the standby mode, or press end key  to exit.

### Handset Language Setting

1. Press right key  to enter the menu.
2. Press up /down  key to select **HS Setting**.
3. Press right key  to confirm. **Register HS** is displayed.
4. Press up /down  key to select **Language**. Press right key  to confirm.
5. Press up /down  key to select among the 8 languages. (Available languages are: Traditional Chinese, Portuguese, Dutch, Spanish, Italian, French, German and English)
6. Press right key  to confirm.
7. Press left key  repeatedly to return to the standby mode, or press end key  to exit.

### Handset Contrast Setting

1. Press right key  to enter the menu.
2. Press up /down  key to select **HS Setting**.
3. Press right key  to confirm. **Register HS** is displayed.
4. Press up /down  key to select **Contrast**. Press right key  to confirm.

5. Press up▲/down▼ key to adjust the contrast level.
6. Press right key▶ to confirm.
7. Press left key◀ repeatedly to return to the standby mode, or press end key⏏ to exit.

### Handset Alarm Setting

1. Press right key▶ to enter the menu.
2. Press up▲/down▼ key to select **HS Setting**.
3. Press right key▶ to confirm. **Register HS** is displayed.
4. Press up▲/down▼ key to select **Alarm**. Press right key▶ to confirm.
5. Press up▲/down▼ key to ON/OFF the Alarm. Press right key▶ to confirm.
6. The time alarm is displayed, such as: "11:50 \*AM".
7. Enter the time you want to set. Press " \* " to switch between AM and PM. Press right key▶ to confirm.
8. Press up▲/down▼ key to select among the 10 alarm melodies. A short melody will be played while you switch to each alarm's melody. Press right key▶ to confirm.
9. Press left key◀ repeatedly to return to the standby mode, or press end key⏏ to exit.

### Handset Key Tone Setting

1. Press right key▶ to enter the menu.
2. Press up▲/down▼ key to select **HS Setting**.
3. Press right key▶ to confirm. **Register HS** is displayed.
4. Press up▲/down▼ key to select **Key Tone**. Press right key▶ to confirm.
5. Press up▲/down▼ key to ON/OFF the key tone. Press right key▶ to confirm.
6. Press left key◀ repeatedly to return to the standby mode, or press end key⏏ to exit.

### Handset Auto Answer

1. Press right key▶ to enter the menu.
2. Press up▲/down▼ key to select **HS Setting**.
3. Press right key▶ to confirm. **Register HS** is displayed.
4. Press up▲/down▼ key to select **Auto Answer**. Press right key▶ to confirm.
5. Press up▲/down▼ key to ON/OFF the Auto Answer. Press right key▶ to confirm.
6. Press left key◀ repeatedly to return to the standby mode, or press end key⏏ to exit.

When the handset is in charging, you can still pick up incoming call by picking up the handset from the charger.

### Keypad Lock

1. In the standby mode, long press \* for 3 seconds or more to activate the keypad lock. The lock symbol  will be displayed in the right corner of the LCD display.
2. Long press \* for 3 seconds or more to deactivate the keypad lock.









## Handset REDIAL Key Function

In standby mode, press **REDIAL** key, the last dialed phone number will be displayed. Press call key  to dial the last dialed phone number.

## Handset R Key Function













In standby mode, long press **R** key for 3 seconds can enter language setting. During an external call, **R** key is the flash function. (You have to contact your local phone service provider to activate this function.)

## Restoring Handset to Factory Default









1. Press right key  to enter the menu.
2. Press up /down  key to select **HS Setting**.
3. Press right key  to confirm.
4. Press up /down  key to select **Reset HS**.
5. Press right key  to confirm.
6. Press key number 1 to confirm, or key number 2 to abort.
7. Press left key  repeatedly to return to the standby mode, or press end key  to exit.

## BASE STATION SETTINGS

### Time and Date











1. Press right key  to enter the menu.
2. Press up /down  key to select **Base Setting**.
3. Press right key  to confirm.
4. Press up /down  key to select **Set Time**.
5. Press right key  to confirm. The time and date formats will be displayed, MM/DD/YYYY and DD/MM/YYYY (24 hour).
6. Press up /down  key to select. Press right key  to confirm. Enter in the following order: month(or date), date(or month), year, hour, minute. If the entered number does not match the required item, you will hear a long beep.
7. Press right key  to confirm.
8. Press left key  repeatedly to return to the standby mode, or press end key  to exit.

### Restoring Base to Factory Default













1. Press right key  to enter the menu.
2. Press up /down  key to select **Base Setting**.
3. Press right key  to confirm.
4. Press up /down  key to select **Reset Base**.
5. Press right key  to confirm.
6. Press key number 1 to confirm, or key number 2 to abort.
7. Press left key  repeatedly to return to the standby mode, or press end key  to exit.

## Call Waiting Tone

When there is an incoming call from an external line during a call in progress, the base will send a series of short beeps to the handsets in use. Use this function to turn the call waiting tone on or off.

1. Press right key  to enter the menu.
2. Press up /down  key to select **Base Setting**.
3. Press right key  to confirm.
4. Press up /down  key to select **Call Waiting**.
5. Press right key  to confirm. **OFF** will be displayed, indicating the call waiting tone is turned off. Press up /down  key to turn the call waiting tone on or off.
6. Press right key  to confirm.
7. Press end key  to exit.

## VOICE ANNOUNCE FUNCTION (DISA)

1. Press right key  to enter the menu.
2. Press up /down  key to select **Base Setting**.
3. Press right key  to confirm.
4. Press up /down  key to select **DISA Setting**. Press right key  to confirm.
5. Handset will display **Please wait**, and then display **ON**.
6. Press up /down  key to ON/OFF the voice announce function. Press right key  to confirm.
7. Press left key  repeatedly to return to the standby mode, or press end key  to exit.

When finish the **DISA Setting**, you have to reset the base power.

If you turn off **DISA** function, all handset will ring when there is an incoming call.

## Handset Menu

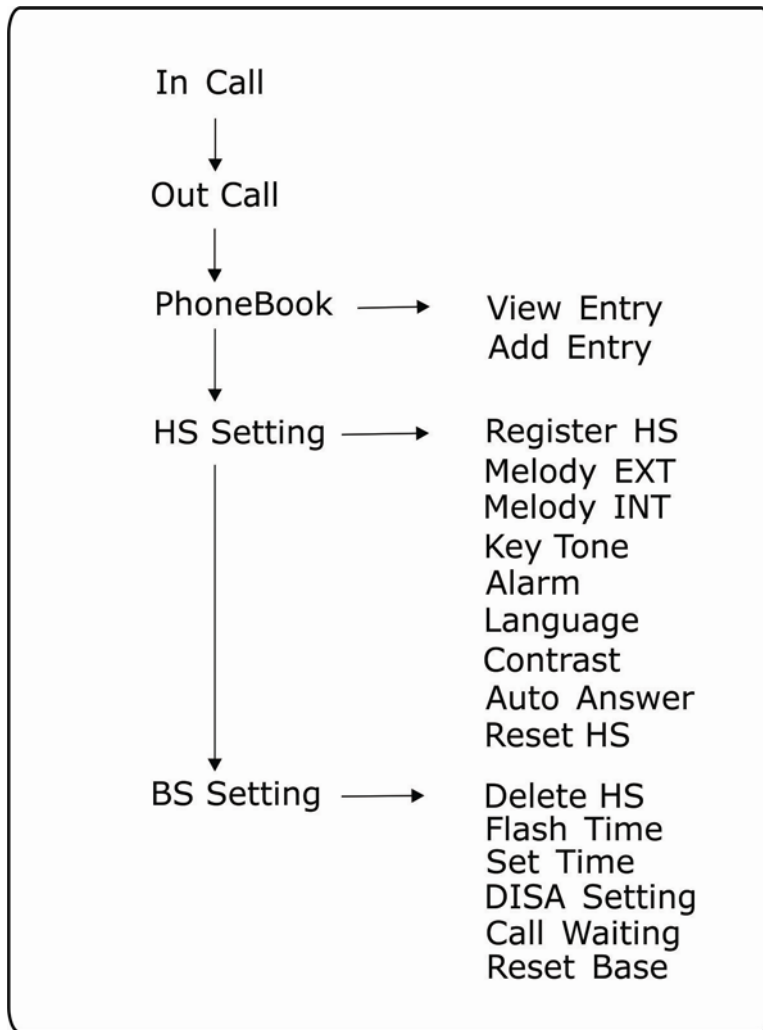

## TROUBLESHOOTING

Error	Solution
The handset cannot be used.	<ul style="list-style-type: none"> <li>● Make sure the power cord of the base station is connected to a power source.</li> <li>● Make sure the batteries are charged and inserted correctly.</li> <li>● Make sure the phone cables are properly connected to the RJ-11 phone jacks.</li> <li>● Make sure the handset is connected to the base station.</li> </ul>
No dial tone.	<ul style="list-style-type: none"> <li>● Make sure the power cord of the base station is connected to a power source.</li> <li>● Make sure the phone cables are properly connected.</li> </ul>
Caller ID is not working.	<ul style="list-style-type: none"> <li>● Contact your local phone service provider.</li> <li>● Wait for the handset to ring at least once before picking up.</li> <li>● If the caller has disabled caller ID on their phone, the phone number will not be displayed.</li> </ul>
Cannot reply to a call.	<ul style="list-style-type: none"> <li>● Make sure your call return settings are correct.</li> </ul>
The battery depletes soon after recharging.	<ul style="list-style-type: none"> <li>● Replace the batteries.</li> </ul>
Cannot transfer a call.	<ul style="list-style-type: none"> <li>● Make sure the handset number you have entered is correct.</li> <li>● Make sure the target handset has been registered to the same base station.</li> </ul>
In standby mode, base Line 1~4 LED sparked	<ul style="list-style-type: none"> <li>● XPS-4010<sup>+</sup> has phone line detect function. It will detect the phone line when the base power on. In standby mode Line 1~4 LED will off. Line LED sparked means that the base did not detect the phone line. Please plug the PSTN phone line once again, then power on the base.</li> </ul>

## FEATURES

- 1.8GHz, Digital Enhanced Cordless Technology
- GAP compliance, compatible with most DECT handsets
- Single cell base with 4 PSTN lines
- Expandable up to 15 cordless handsets
- Supports 4 active handsets
- Phone line auto searching
- Caller ID FSK/DTMF available
- Voice announce function(DISA)
- Handset intercom
- Call transfer to other handset
- LCD display
- Phonebook with 60 sets dialing memory
- 30 incoming call logs
- 30 outgoing call logs
- Handset speakerphone function
- Adjustable earphone and ringer volume
- Multi-language (8 languages)
- Off hook dialing and Pre-dialing
- Call timer display
- Out of range tone
- Low battery tone indicator
- Keypad lock function
- Alarm function
- Handset clock protect mode

## TECHNICAL SPECIFICATIONS

Frequency	Taiwan: 1880-1895MHz
Frequency modulation	GFSK
Air interface	TDMA/TDD
Channel space	1.728MHz
Carrier frequency offset	< $\pm$ 50KHz
Output power	Max. 250mW Avg. 10mW
Charging time	12 hrs
Temperature	Normal: 15°C~35°C Special: 0°C~40°C
Humidity	0%~90%
Dimensions(mm)	Base: 210x183x50 Handset: 160x46x22
Power	Base input: DC9V 0.5A HS charger: DC7V 0.42A HS Battery: Ni-MH 1.2Vx2,600mAh

